

Сверла с пластинами



Тип	Размеры (мм)					Пластина	Запчасти	
	D	L1	L	L2	d		винт	ключ
TD2-32.5-32-SP09	32.5	32	149	67	89	SP**090408	M3.5*10	T15
TD2-33-32-SP09	33	32	150	68	90	SP**090408		
TD2-33.5-32-SP09	33.5	32	151	69	91	SP**090408		
TD2-56-40-SP09	56	40	211	114	141	SP**090408		
TD2-57-40-SP09	57	40	213	116	143	SP**090408		
TD2-58-40-SP09	58	40	215	118	145	SP**090408		
TD2-59-40-SP09	59	40	218	120	148	SP**090408		
TD2-60-40-SP09	60	40	220	122	150	SP**090408		
TD2-34-32-SP11	34	32	156	70	96	SP**110408		
TD2-34.5-32-SP11	34.5	32	157	71	97	SP**110408		
TD2-35-32-SP11	35	32	158	72	98	SP**110408		
TD2-35.5-32-SP11	35.5	32	159	73	99	SP**110408		
TD2-36-32-SP11	36	32	160	74	100	SP**110408		
TD2-36.5-32-SP11	36.5	32	161	75	101	SP**110408		
TD2-37-32-SP11	37	32	161	76	101	SP**110408		
TD2-37.5-32-SP11	37.5	32	162	77	102	SP**110408		
TD2-38-32-SP11	38	32	163	78	103	SP**110408		
TD2-38.5-32-SP11	38.5	32	164	79	104	SP**110408		
TD2-39-32-SP11	39	32	165	80	105	SP**110408		
TD2-39.5-32-SP11	39.5	32	166	81	106	SP**110408		
TD2-40-32-SP11	40	32	167	82	107	SP**110408		
TD2-40.5-32-SP11	40.5	32	168	83	108	SP**110408		
TD2-41-32-SP11	41	32	169	84	109	SP**110408		
TD2-42-40-SP14	42	40	179	86	109	SP**140512		
TD2-43-40-SP14	43	40	181	88	111	SP**140512		
TD2-44-40-SP14	44	40	186	90	116	SP**140512		
TD2-45-40-SP14	45	40	188	92	118	SP**140512		
TD2-46-40-SP14	46	40	191	94	121	SP**140512		
TD2-47-40-SP14	47	40	193	96	123	SP**140512		
TD2-48-40-SP14	48	40	195	98	125	SP**140512		
TD2-49-40-SP14	49	40	197	100	127	SP**140512		
TD2-50-40-SP14	50	40	199	102	129	SP**140512		

Пластины

Обозначение			Обозначение	Подача, мм/об
ISO P	ISO M	ISO K	ISO N	
SPMG050204-TZ-TU6030			SPGT050204-TU1025	0,05-0,09
SPMG060204-TZ-TU6030			SPGT060204-TU1025	0,05-0,09
SPMG07T308-TZ-TU6030			SPGT07T308-TU1025	0,06-0,10
SPMG090408-TZ-TU6030			SPGT090408-TU1025	0,08-0,16
SPMG110408-TZ-TU6030			SPGT110408-TU1025	0,10-0,20
SPMG140512-TZ-TU6030			SPGT140512-TU1025	0,12-0,24

P (Стали)				M (Нержавеющие стали)		K (Чугуны)			N
Углерод	Низколег.	Высоколег.	Улучш.	Мартенсит.	Аустенит.	Ковкий	Серый	ВЧШГ	Al и Cu
170-240	140-220	120-180	120-170	110-230	110-220	120-220	170-240	130-200	250-300



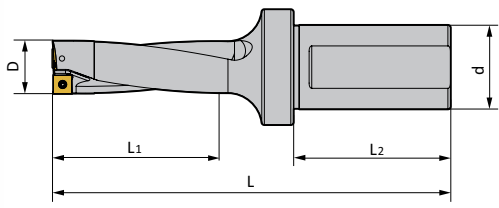

Тип	Размеры (мм)					Пластина	Запчасти	
	D	L1	L	L2	d		винт	ключ
TD3-12.5-20-SP05	12.5	20	108.5	39.5	58.5	SP**050204	M2.2*5	T6
TD3-13-20-SP05	13	20	110	96	60	SP**050204		
TD3-13.5-20-SP05	13.5	20	111.5	42.5	61.5	SP**050204		
TD3-14-25-SP05	14	25	121	44	65	SP**050204		
TD3-14.5-25-SP05	14.5	25	122.5	45.5	66.5	SP**050204		
TD3-15-25-SP05	15	25	124	47	68	SP**050204		
TD3-15.5-25-SP05	15.5	25	125.5	48.5	69.5	SP**050204	M2.2*6	T7
TD3-16-25-SP06	16	25	127	50	71	SP**060204		
TD3-16.5-25-SP06	16.5	25	128.5	51.5	72.5	SP**060204		
TD3-17-25-SP06	17	25	128	53	72	SP**060204		
TD3-17.5-25-SP06	17.5	25	129.5	54.5	73.5	SP**060204		
TD3-18-25-SP06	18	25	130	56	74	SP**060204		
TD3-18.5-25-SP06	18.5	25	131.5	57.5	75.5	SP**060204		
TD3-19-25-SP06	19	25	132	59	76	SP**060204		
TD3-19.5-25-SP06	19.5	25	133.5	60.5	77.5	SP**060204		
TD3-20-25-SP06	20	25	137	62	81	SP**060204		
TD3-20.5-25-SP06	20.5	25	138.5	63.5	82.5	SP**060204		
TD3-21-25-SP06	21	25	140	65	84	SP**060204		
TD3-21.5-25-SP06	21.5	25	141.5	66.5	85.5	SP**060204	M2.5*8	T8
TD3-22-25-SP07	22	25	143	68	87	SP**07T308		
TD3-22.5-25-SP07	22.5	25	144.5	69.5	88.5	SP**07T308		
TD3-23-25-SP07	23	25	146	71	90	SP**07T308		
TD3-23.5-25-SP07	23.5	25	147.5	72.5	91.5	SP**07T308		
TD3-24-25-SP07	24	25	149	74	93	SP**07T308		
TD3-24.5-25-SP07	24.5	25	150.5	75.5	94.5	SP**07T308		
TD3-25-25-SP07	25	25	153	77	97	SP**07T308		
TD3-25-32-SP07	25	32	162	77	102	SP**07T308		
TD3-25.5-32-SP07	25.5	32	163.5	78.5	103.5	SP**07T308		
TD3-26-32-SP07	26	32	165	80	105	SP**07T308		
TD3-26.5-32-SP07	26.5	32	166.5	81.5	106.5	SP**07T308		
TD3-27-32-SP07	27	32	168	83	108	SP**07T308		
TD3-27.5-32-SP07	27.5	32	169.5	84.5	109.5	SP**07T308		
TD3-51-40-SP07	51	40	252	155	182	SP**07T308		
TD3-52-40-SP07	52	40	255	158	185	SP**07T308		
TD3-53-40-SP07	53	40	258	161	188	SP**07T308		
TD3-54-40-SP07	54	40	261	164	191	SP**07T308		
TD3-55-40-SP07	55	40	264	167	194	SP**07T308		
TD3-28-32-SP09	28	32	171	86	111	SP**090408	M3.5*10	T15
TD3-28.5-32-SP09	28.5	32	172.5	87.5	112.5	SP**090408		
TD3-29-32-SP09	29	32	174	89	114	SP**090408		
TD3-29.5-32-SP09	29.5	32	175.5	96.0	115.5	SP**090408		
TD3-30-32-SP09	30	32	174	92	114	SP**090408		
TD3-30.5-32-SP09	30.5	32	175.5	93.5	115.5	SP**090408		
TD3-31-32-SP09	31	32	177	95	117	SP**090408		
TD3-31.5-32-SP09	31.5	32	178.5	96.5	118.5	SP**090408		
TD3-32-32-SP09	32	32	180	98	120	SP**090408		

Тип	Размеры (мм)					Пластина	Запчасти	
	D	L1	L	L2	d		винт	ключ
TD3-32.5-32-SP09	32.5	32	181.5	99.5	121.5	SP**090408	M3.5*10	T15
TD3-33-32-SP09	33	32	183	101	123	SP**090408		
TD3-33.5-32-SP09	33.5	32	184.5	102.5	124.5	SP**090408		
TD3-56-40-SP09	56	40	267	170	197	SP**090408		
TD3-57-40-SP09	57	40	270	173	200	SP**090408		
TD3-58-40-SP09	58	40	273	176	203	SP**090408		
TD3-59-40-SP09	59	40	277	179	207	SP**090408		
TD3-60-40-SP09	60	40	280	182	210	SP**090408		
TD3-34-32-SP11	34	32	191.5	104	131.5	SP**110408		
TD3-34.5-32-SP11	34.5	32	191.5	105.5	131.5	SP**110408		
TD3-35-32-SP11	35	32	193	107	133	SP**110408		
TD3-35.5-32-SP11	35.5	32	194.5	108.5	134.5	SP**110408		
TD3-36-32-SP11	36	32	196	110	136	SP**110408		
TD3-36.5-32-SP11	36.5	32	197.5	111.5	137.5	SP**110408		
TD3-37-32-SP11	37	32	198	113	138	SP**110408		
TD3-37.5-32-SP11	37.5	32	199.5	114.5	139.5	SP**110408		
TD3-38-32-SP11	38	32	201	116	141	SP**110408		
TD3-38.5-32-SP11	38.5	32	202.5	117.5	142.5	SP**110408		
TD3-39-32-SP11	39	32	204	119	144	SP**110408		
TD3-39.5-32-SP11	39.5	32	205.5	120.5	145.5	SP**110408		
TD3-40-32-SP11	40	32	207	122	147	SP**110408		
TD3-40.5-32-SP11	40.5	32	208.5	123.5	148.5	SP**110408		
TD3-41-32-SP11	41	32	210	125	150	SP**110408		
TD3-42-40-SP14	42	40	221	128	151	SP**140512		
TD3-43-40-SP14	43	40	224	131	154	SP**140512		
TD3-44-40-SP14	44	40	230	134	160	SP**140512		
TD3-45-40-SP14	45	40	233	137	163	SP**140512		
TD3-46-40-SP14	46	40	237	140	167	SP**140512		
TD3-47-40-SP14	47	40	240	143	170	SP**140512		
TD3-48-40-SP14	48	40	243	146	173	SP**140512		
TD3-49-40-SP14	49	40	246	149	176	SP**140512		
TD3-50-40-SP14	50	40	249	152	179	SP**140512		

Пластины

Обозначение			Обозначение	Подача, мм/об
ISO P	ISO M	ISO K	ISO N	
SPMG050204-TZ-TU6030			SPGT050204-TU1025	0,05-0,09
SPMG060204-TZ-TU6030			SPGT060204-TU1025	0,05-0,09
SPMG07T308-TZ-TU6030			SPGT07T308-TU1025	0,06-0,10
SPMG090408-TZ-TU6030			SPGT090408-TU1025	0,08-0,16
SPMG110408-TZ-TU6030			SPGT110408-TU1025	0,10-0,20
SPMG140512-TZ-TU6030			SPGT140512-TU1025	0,12-0,24

P (Стали)				M (Нержавеющие стали)		K (Чугуны)			N
Углерод.	Низколег.	Высоколег.	Улучш.	Мартенсит.	Аустенит.	Ковкий	Серый	ВЧШГ	Al и Cu
170-240	140-220	120-180	120-170	110-230	110-220	120-220	170-240	130-200	250-300



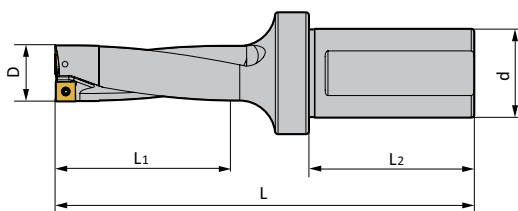

Тип	Размеры (мм)					Пластина	Запчасти	
	D	L1	L	L2	d		винт	ключ
TD4-12.5-20-SP05	12.5	20	121	52	71	SP**050204	M2.2*5	T6
TD4-13-20-SP05	13	20	123	96	73	SP**050204		
TD4-13.5-20-SP05	13.5	20	125	56	75	SP**050204		
TD4-14-25-SP05	14	25	135	58	79	SP**050204		
TD4-14.5-25-SP05	14.5	25	137	60	81	SP**050204		
TD4-15-25-SP05	15	25	139	62	83	SP**050204		
TD4-15.5-25-SP05	15.5	25	141	64	85	SP**050204	M2.2*6	T7
TD4-16-25-SP06	16	25	143	66	87	SP**060204		
TD4-16.5-25-SP06	16.5	25	145	68	89	SP**060204		
TD4-17-25-SP06	17	25	145	70	89	SP**060204		
TD4-17.5-25-SP06	17.5	25	147	72	91	SP**060204		
TD4-18-25-SP06	18	25	148	74	92	SP**060204		
TD4-18.5-25-SP06	18.5	25	150	76	94	SP**060204		
TD4-19-25-SP06	19	25	151	78	95	SP**060204		
TD4-19.5-25-SP06	19.5	25	153	80	97	SP**060204		
TD4-20-25-SP06	20	25	157	82	101	SP**060204		
TD4-20.5-25-SP06	20.5	25	159	84	103	SP**060204		
TD4-21-25-SP06	21	25	161	86	105	SP**060204		
TD4-21.5-25-SP06	21.5	25	163	88	107	SP**060204		
TD4-22-25-SP07	22	25	165	90	109	SP**07T308		
TD4-22.5-25-SP07	22.5	25	167	92	111	SP**07T308		
TD4-23-25-SP07	23	25	169	94	113	SP**07T308		
TD4-23.5-25-SP07	23.5	25	171	96	115	SP**07T308		
TD4-24-25-SP07	24	25	173	98	117	SP**07T308		
TD4-24.5-25-SP07	24.5	25	175	100	119	SP**07T308		
TD4-25-25-SP07	25	25	178	102	122	SP**07T308		
TD4-25-32-SP07	25	32	187	102	127	SP**07T308		
TD4-25.5-32-SP07	25.5	32	189	104	129	SP**07T308		
TD4-26-32-SP07	26	32	191	106	131	SP**07T308		
TD4-26.5-32-SP07	26.5	32	193	108	133	SP**07T308		
TD4-27-32-SP07	27	32	195	110	135	SP**07T308		
TD4-27.5-32-SP07	27.5	32	197	112	137	SP**07T308		
TD4-51-40-SP07	51	40	303	206	233	SP**07T308		
TD4-52-40-SP07	52	40	307	210	237	SP**07T308		
TD4-53-40-SP07	53	40	311	214	241	SP**07T308		
TD4-54-40-SP07	54	40	315	218	245	SP**07T308		
TD4-55-40-SP07	55	40	319	222	249	SP**07T308		
TD4-28-32-SP09	28	32	199	114	139	SP**090408	M3.5*10	T15
TD4-28.5-32-SP09	28.5	32	201	116	141	SP**090408		
TD4-29-32-SP09	29	32	203	118	143	SP**090408		
TD4-29.5-32-SP09	29.5	32	205	96	145	SP**090408		
TD4-30-32-SP09	30	32	204	122	144	SP**090408		
TD4-30.5-32-SP09	30.5	32	206	124	146	SP**090408		
TD4-31-32-SP09	31	32	208	126	148	SP**090408		
TD4-31.5-32-SP09	31.5	32	210	128	150	SP**090408		
TD4-32-32-SP09	32	32	212	130	152	SP**090408		



Тип	Размеры (мм)					Пластина	Запчасти	
	D	L1	L	L2	d		винт	ключ
TD4-32.5-32-SP09	32.5	32	214	132	154	SP**090408	M3.5*10	T15
TD4-33-32-SP09	33	32	216	134	156	SP**090408		
TD4-33.5-32-SP09	33.5	32	218	136	158	SP**090408		
TD4-56-40-SP09	56	40	323	226	253	SP**090408		
TD4-57-40-SP09	57	40	327	230	257	SP**090408		
TD4-58-40-SP09	58	40	331	234	261	SP**090408		
TD4-59-40-SP09	59	40	336	238	266	SP**090408		
TD4-60-40-SP09	60	40	340	242	270	SP**090408		
TD4-34-32-SP11	34	32	224	138	164	SP**110408		
TD4-34.5-32-SP11	34.5	32	226	140	166	SP**110408		
TD4-35-32-SP11	35	32	228	142	168	SP**110408		
TD4-35.5-32-SP11	35.5	32	230	144	170	SP**110408		
TD4-36-32-SP11	36	32	232	146	172	SP**110408		
TD4-36.5-32-SP11	36.5	32	234	148	174	SP**110408		
TD4-37-32-SP11	37	32	235	150	175	SP**110408		
TD4-37.5-32-SP11	37.5	32	237	152	177	SP**110408		
TD4-38-32-SP11	38	32	239	154	179	SP**110408		
TD4-38.5-32-SP11	38.5	32	241	156	181	SP**110408		
TD4-39-32-SP11	39	32	243	158	183	SP**110408		
TD4-39.5-32-SP11	39.5	32	245	160	185	SP**110408		
TD4-40-32-SP11	40	32	247	162	187	SP**110408		
TD4-40.5-32-SP11	40.5	32	249	164	189	SP**110408		
TD4-41-32-SP11	41	32	251	166	191	SP**110408		
TD4-42-40-SP14	42	40	263	170	193	SP**140512		
TD4-43-40-SP14	43	40	267	174	197	SP**140512		
TD4-44-40-SP14	44	40	274	178	204	SP**140512		
TD4-45-40-SP14	45	40	278	182	208	SP**140512		
TD4-46-40-SP14	46	40	283	186	213	SP**140512		
TD4-47-40-SP14	47	40	287	190	217	SP**140512		
TD4-48-40-SP14	48	40	291	194	221	SP**140512		
TD4-49-40-SP14	49	40	295	198	225	SP**140512		
TD4-50-40-SP14	50	40	299	202	229	SP**140512		

Пластины

Обозначение			Обозначение	Подача, мм/об
ISO P	ISO M	ISO K	ISO N	
SPMG050204-TZ-TU6030			SPGT050204-TU1025	0,05-0,09
SPMG060204-TZ-TU6030			SPGT060204-TU1025	0,05-0,09
SPMG07T308-TZ-TU6030			SPGT07T308-TU1025	0,06-0,10
SPMG090408-TZ-TU6030			SPGT090408-TU1025	0,08-0,16
SPMG110408-TZ-TU6030			SPGT110408-TU1025	0,10-0,20
SPMG140512-TZ-TU6030			SPGT140512-TU1025	0,12-0,24

P (Стали)				M (Нержавеющие стали)		K (Чугуны)			N
Углерод.	Низколег.	Высоколег.	Улучш.	Мартенсит.	Аустенит.	Ковкий	Серый	ВЧШГ	Al и Cu
170-240	140-220	120-180	120-170	110-230	110-220	120-220	170-240	130-200	250-300



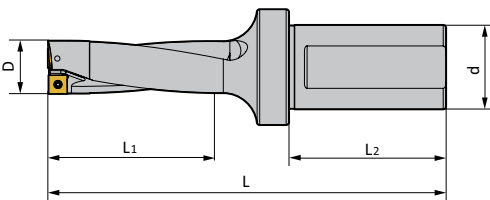

Тип	Размеры (мм)					Пластина	Запчасти	
	D	L1	L	L2	d		винт	ключ
TD5-12.5-20-SP05	12.5	20	133.5	64.5	83.5	SP**050204	M2.2*5	T6
TD5-13-20-SP05	13	20	136	96	86	SP**050204		
TD5-13.5-20-SP05	13.5	20	138.5	69.5	88.5	SP**050204		
TD5-14-25-SP05	14	25	149	72	93	SP**050204		
TD5-14.5-25-SP05	14.5	25	151.5	74.5	95.5	SP**050204		
TD5-15-25-SP05	15	25	154	77	98	SP**050204		
TD5-15.5-25-SP05	15.5	25	156.5	79.5	100.5	SP**050204	M2.2*6	T7
TD5-16-25-SP06	16	25	159	82	103	SP**060204		
TD5-16.5-25-SP06	16.5	25	161.5	84.5	105.5	SP**060204		
TD5-17-25-SP06	17	25	162	87	106	SP**060204		
TD5-17.5-25-SP06	17.5	25	164.5	89.5	108.5	SP**060204		
TD5-18-25-SP06	18	25	166	92	110	SP**060204		
TD5-18.5-25-SP06	18.5	25	168.5	94.5	112.5	SP**060204		
TD5-19-25-SP06	19	25	170	97	114	SP**060204		
TD5-19.5-25-SP06	19.5	25	172.5	99.5	116.5	SP**060204		
TD5-20-25-SP06	20	25	177	102	121	SP**060204		
TD5-20.5-25-SP06	20.5	25	179.5	104.5	123.5	SP**060204		
TD5-21-25-SP06	21	25	182	107	126	SP**060204		
TD5-21.5-25-SP06	21.5	25	184.5	109.5	128.5	SP**060204		
TD5-22-25-SP07	22	25	187	112	131	SP**07T308	M2.5*8	T8
TD5-22.5-25-SP07	22.5	25	189.5	114.5	133.5	SP**07T308		
TD5-23-25-SP07	23	25	192	117	136	SP**07T308		
TD5-23.5-25-SP07	23.5	25	194.5	119.5	138.5	SP**07T308		
TD5-24-25-SP07	24	25	197	122	141	SP**07T308		
TD5-24.5-25-SP07	24.5	25	199.5	124.5	143.5	SP**07T308		
TD5-25-25-SP07	25	25	203	127	147	SP**07T308		
TD5-25-32-SP07	25.5	32	214.5	129.5	154.5	SP**07T308		
TD5-26-32-SP07	26	32	217	132	157	SP**07T308		
TD5-26.5-32-SP07	26.5	32	219.5	134.5	159.5	SP**07T308		
TD5-27-32-SP07	27	32	222	137	162	SP**07T308		
TD5-27.5-32-SP07	27.5	32	224.5	139.5	164.5	SP**07T308		
TD5-51-40-SP07	51	40	354	257	284	SP**07T308		
TD5-52-40-SP07	52	40	359	262	289	SP**07T308		
TD5-53-40-SP07	53	40	364	267	294	SP**07T308		
TD5-54-40-SP07	54	40	369	272	299	SP**07T308		
TD5-55-40-SP07	55	40	374	277	304	SP**07T308		
TD5-28-32-SP09	28	32	227	142	167	SP**090408		
TD5-28.5-32-SP09	28.5	32	229.5	144.5	169.5	SP**090408		
TD5-29-32-SP09	29	32	232	147	172	SP**090408		
TD5-29.5-32-SP09	29.5	32	234.5	149.5	174.5	SP**090408		
TD5-30-32-SP09	30	32	237	150	175	SP**090408		
TD5-30.5-32-SP09	30.5	32	239.5	152.5	177.5	SP**090408		
TD5-31-32-SP09	31	32	242	154	179	SP**090408		
TD5-31.5-32-SP09	31.5	32	244.5	156.5	181.5	SP**090408		
TD5-32-32-SP09	32	32	247	157	182	SP**090408		
TD5-32-32-SP09	32	32	244	162	184	SP**090408		



Тип	Размеры (мм)					Пластина	Запчасти	
	D	L1	L	L2	d		винт	ключ
TD5-32.5-32-SP09	32.5	32	246.5	164.5	186.5	SP**090408	M3.5*10	T15
TD5-33-32-SP09	33	32	249	167	189	SP**090408		
TD5-33.5-32-SP09	33.5	32	251.5	169.5	191.5	SP**090408		
TD5-56-40-SP09	56	40	379	282	309	SP**090408		
TD5-57-40-SP09	57	40	384	287	314	SP**090408		
TD5-58-40-SP09	58	40	389	292	319	SP**090408		
TD5-59-40-SP09	59	40	395	297	325	SP**090408		
TD5-60-40-SP09	60	40	400	302	330	SP**090408		
TD5-34-32-SP11	34	32	258	172	198	SP**110408		
TD5-34.5-32-SP11	34.5	32	260.5	174.5	200.5	SP**110408		
TD5-35-32-SP11	35	32	263	177	203	SP**110408		
TD5-35.5-32-SP11	35.5	32	265.5	179.5	205.5	SP**110408		
TD5-36-32-SP11	36	32	268	182	208	SP**110408		
TD5-36.5-32-SP11	36.5	32	270.5	184.5	210.5	SP**110408		
TD5-37-32-SP11	37	32	272	187	212	SP**110408		
TD5-37.5-32-SP11	37.5	32	274.5	189.5	214.5	SP**110408		
TD5-38-32-SP11	38	32	277	192	217	SP**110408		
TD5-38.5-32-SP11	38.5	32	279.5	194.5	219.5	SP**110408		
TD5-39-32-SP11	39	32	282	197	222	SP**110408		
TD5-39.5-32-SP11	39.5	32	284.5	199.5	224.5	SP**110408		
TD5-40-32-SP11	40	32	287	202	227	SP**110408		
TD5-40.5-32-SP11	40.5	32	289.5	204.5	229.5	SP**110408		
TD5-41-32-SP11	41	32	292	207	232	SP**110408		
TD5-42-40-SP14	42	40	305	212	235	SP**140512		
TD5-43-40-SP14	43	40	310	217	240	SP**140512		
TD5-44-40-SP14	44	40	318	222	248	SP**140512		
TD5-45-40-SP14	45	40	323	227	253	SP**140512		
TD5-46-40-SP14	46	40	329	232	259	SP**140512		
TD5-47-40-SP14	47	40	334	237	264	SP**140512		
TD5-48-40-SP14	48	40	339	242	269	SP**140512		
TD5-49-40-SP14	49	40	344	247	274	SP**140512		
TD5-50-40-SP14	50	40	349	252	279	SP**140512		

Пластины

Обозначение			Обозначение	Подача, мм/об
ISO P	ISO M	ISO K	ISO N	
SPMG050204-TZ-TU6030			SPGT050204-TU1025	0,05-0,09
SPMG060204-TZ-TU6030			SPGT060204-TU1025	0,05-0,09
SPMG07T308-TZ-TU6030			SPGT07T308-TU1025	0,06-0,10
SPMG090408-TZ-TU6030			SPGT090408-TU1025	0,08-0,16
SPMG110408-TZ-TU6030			SPGT110408-TU1025	0,10-0,20
SPMG140512-TZ-TU6030			SPGT140512-TU1025	0,12-0,24

P (Стали)				M (Нержавеющие стали)		K (Чугуны)			N
Углерод.	Низколег.	Высоколег.	Улучш.	Мартенсит.	Аустенит.	Ковкий	Серый	ВЧШГ	Al и Cu
170-240	140-220	120-180	120-170	110-230	110-220	120-220	170-240	130-200	250-300



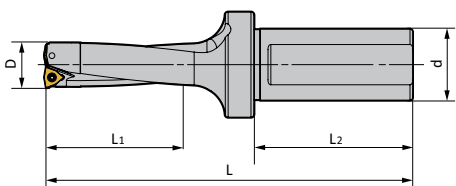

Тип	Размеры (мм)					Пластина	Запчасти	
	D	L1	L	L2	d		винт	ключ
TD2-14-25-WC03	14	25	107	30	51	WC**030208	M2.5*5	T8
TD2-14.5-25-WC03	14.5	25	108	31	52	WC**030208	M2.5*6	T8
TD2-15-25-WC03	15	25	107	32	51	WC**030208		
TD2-15.5-25-WC03	15.5	25	108	33	52	WC**030208		
TD2-16-25-WC03	16	25	109	34	53	WC**030208		
TD2-16.5-25-WC03	16.5	25	110	35	54	WC**030208		
TD2-17-25-WC03	17	25	111	36	55	WC**030208		
TD2-17.5-25-WC03	17.5	25	112	37	56	WC**030208		
TD2-18-25-WC03	18	25	113	38	57	WC**030208		
TD2-18.5-25-WC03	18.5	25	114	39	58	WC**030208		
TD2-19-25-WC03	19	25	113	40	57	WC**030208		
TD2-19.5-25-WC04	19.5	25	114	41	58	WC**040208		
TD2-20-25-WC04	20	25	115.5	42	59.5	WC**040208		
TD2-20.5-25-WC04	20.5	25	117	43	61	WC**040208		
TD2-21-25-WC04	21	25	118	44	62	WC**040208		
TD2-21.5-25-WC04	21.5	25	119	45	63	WC**040208		
TD2-22-25-WC04	22	25	120	46	64	WC**040208		
TD2-22.5-25-WC04	22.5	25	121	47	65	WC**040208		
TD2-23-25-WC04	23	25	122	48	66	WC**040208		
TD2-23.5-25-WC04	23.5	25	123	49	67	WC**040208		
TD2-24-25-WC05	24	25	124	50	68	WC**050308		
TD2-24.5-25-WC05	24.5	25	125	51	69	WC**050308		
TD2-25-25-WC05	25	25	127	52	71	WC**050308		
TD2-25-32-WC05	25	32	136	52	76	WC**050308		
TD2-25.5-32-WC05	25.5	32	137	53	77	WC**050308		
TD2-26-32-WC05	26	32	138	54	78	WC**050308		
TD2-26.5-32-WC05	26.5	32	139	55	79	WC**050308		
TD2-27-32-WC05	27	32	140	56	80	WC**050308		
TD2-27.5-32-WC05	27.5	32	141	57	81	WC**050308		
TD2-28-32-WC05	28	32	142	58	82	WC**050308		
TD2-28.5-32-WC05	28.5	32	143	59	83	WC**050308		
TD2-29-32-WC05	29	32	144	60	84	WC**050308		
TD2-29.5-32-WC05	29.5	32	145	61	85	WC**050308		
TD2-30-32-WC05	30	32	146	62	86	WC**050308		
TD2-30.5-32-WC05	30.5	32	146	63	86	WC**050308		
TD2-31-32-WC06	31	32	147	64	87	WC**06T308		
TD2-31.5-32-WC06	31.5	32	147	65	87	WC**06T308		
TD2-32-32-WC06	32	32	149	66	89	WC**06T308		
TD2-32.5-32-WC06	32.5	32	149	67	89	WC**06T308		
TD2-33-32-WC06	33	32	151	68	91	WC**06T308		
TD2-33.5-32-WC06	33.5	32	151	69	91	WC**06T308		
TD2-34-32-WC06	34	32	152	70	92	WC**06T308		
TD2-34.5-32-WC06	34.5	32	152	71	92	WC**06T308		
TD2-35-32-WC06	35	32	155	72	95	WC**06T308		
TD2-35.5-32-WC06	35.5	32	155	73	95	WC**06T308		
TD2-36-32-WC06	36	32	157	74	97	WC**06T308		
TD2-36.5-32-WC06	36.5	32	158	75	98	WC**06T308		
TD2-37-32-WC06	37	32	159	76	99	WC**06T308		



Тип	Размеры (мм)					Пластина	Запчасти			
	D	L1	L	L2	d		винт	ключ		
TD2-37.5-32-WC06	37.5	32	161	77	101	WC**06T308	M3.5*10	T15		
TD2-38-32-WC06	38	32	158.5	78	98.5	WC**06T308				
TD2-38.5-32-WC06	38.5	32	159.5	79	99.5	WC**06T308				
TD2-39-32-WC06	39	32	162	80	102	WC**06T308				
TD2-39.5-32-WC06	39.5	32	160	81	100	WC**06T308				
TD2-40-32-WC06	40	32	160	82	100	WC**06T308				
TD2-40.5-32-WC06	40.5	32	160	83	100	WC**06T308				
TD2-41-32-WC06	41	32	164	84	104	WC**06T308				
TD2-41.5-32-WC06	41.5	32	162	85	102	WC**06T308				
TD2-65-40-WC06	65	40	233.5	132	163.5	WC**06T308				
TD2-68-40-WC06	68	40	240	138	170	WC**06T308				
TD2-70-40-WC06	70	40	232	142	162	WC**06T308				
TD2-42-40-WC08	42	40	181	86	111	WC**080412			M4.0*10	T15
TD2-42.5-40-WC08	42.5	40	182	87	112	WC**080412				
TD2-43-40-WC08	43	40	183	88	113	WC**080412				
TD2-43.5-40-WC08	43.5	40	184	89	114	WC**080412				
TD2-44-40-WC08	44	40	185	90	115	WC**080412				
TD2-44.5-40-WC08	44.5	40	186	91	116	WC**080412				
TD2-45-40-WC08	45	40	187	92	117	WC**080412				
TD2-45.5-40-WC08	45.5	40	188	93	118	WC**080412				
TD2-46-40-WC08	46	40	189	94	119	WC**080412				
TD2-46.5-40-WC08	46.5	40	190	95	120	WC**080412				
TD2-47-40-WC08	47	40	191	96	121	WC**080412				
TD2-47.5-40-WC08	47.5	40	192	97	122	WC**080412				
TD2-48-40-WC08	48	40	193	98	123	WC**080412				
TD2-48.5-40-WC08	48.5	40	194	99	124	WC**080412				
TD2-49-40-WC08	49	40	195	100	125	WC**080412				
TD2-49.5-40-WC08	49.5	40	196	101	126	WC**080412				
TD2-50-40-WC08	50	40	197	102	127	WC**080412				
TD2-50.5-40-WC08	50.5	40	197	103	127	WC**080412				
TD2-51-40-WC08	51	40	199	104	129	WC**080412				
TD2-52-40-WC08	52	40	201	106	131	WC**080412				
TD2-53-40-WC08	53	40	203	108	133	WC**080412				
TD2-54-40-WC08	54	40	205	110	135	WC**080412				
TD2-55-40-WC08	55	40	207	112	137	WC**080412				
TD2-56-40-WC08	56	40	209	114	139	WC**080412				
TD2-57-40-WC08	57	40	211	116	141	WC**080412				
TD2-58-40-WC08	58	40	213	118	143	WC**080412				
TD2-59-40-WC08	59	40	215	120	145	WC**080412				
TD2-60-40-WC08	60	40	217	122	147	WC**080412				

Пластины

Обозначение			Обозначение	Подача, мм/об
ISO P	ISO M	ISO K	ISO N	
WCMX030208-TM120			WCGX030208-AL-TN110	0,05-0,09
WCMX040208-TM120			WCGX040208-AL-TN110	0,05-0,09
WCMX050308-TM120			WCGX050308-AL-TN110	0,06-0,10
WCMX06T308-TM120			WCGX06T308-AL-TN110	0,08-0,16
WCMX080412-TM120			WCGX080412-AL-TN110	0,10-0,20

P (Стали)				M (Нержавеющие стали)		K (Чугуны)			N
Углерод.	Низколег.	Высоколег.	Улучш.	Мартенсит.	Аустенит.	Ковкий	Серый	ВЧШГ	Al и Cu
170-240	140-220	120-180	120-170	110-230	110-220	120-220	170-240	130-200	250-300



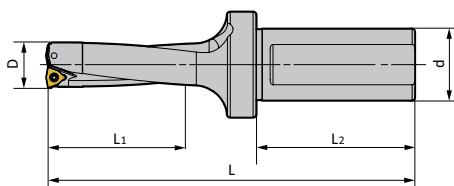

Тип	Размеры (мм)					Пластина	Запчасти	
	D	L1	L	L2	d		винт	ключ
TD3-14-25-WC03	14	25	121	44	65	WC**030208	M2.5*5	T8
TD3-14.5-25-WC03	14.5	25	122.5	45.5	66.5	WC**030208	M2.5*6	T8
TD3-15-25-WC03	15	25	122	47	66	WC**030208		
TD3-15.5-25-WC03	15.5	25	123.5	48.5	67.5	WC**030208		
TD3-16-25-WC03	16	25	125	50	69	WC**030208		
TD3-16.5-25-WC03	16.5	25	126.5	51.5	70.5	WC**030208		
TD3-17-25-WC03	17	25	128	53	72	WC**030208		
TD3-17.5-25-WC03	17.5	25	129.5	54.5	73.5	WC**030208		
TD3-18-25-WC03	18	25	131.	56	75	WC**030208		
TD3-18.5-25-WC03	18.5	25	132.5	57.5	76.5	WC**030208		
TD3-19-25-WC03	19	25	132	59	76	WC**030208		
TD3-19.5-25-WC04	19.5	25	133.5	60.5	77.5	WC**040208	M3.0*8	T8
TD3-20-25-WC04	20	25	135.5	62	79.5	WC**040208		
TD3-20.5-25-WC04	20.5	25	137.5	63.5	81.5	WC**040208		
TD3-21-25-WC04	21	25	139	65	83	WC**040208		
TD3-21.5-25-WC04	21.5	25	140.5	66.5	84.5	WC**040208		
TD3-22-25-WC04	22	25	142	68	86	WC**040208		
TD3-22.5-25-WC04	22.5	25	143.5	69.5	87.5	WC**040208		
TD3-23-25-WC04	23	25	145	71	89	WC**040208		
TD3-23.5-25-WC04	23.5	25	146.5	72.5	90.5	WC**040208		
TD3-24-25-WC05	24	25	148	74	92	WC**050308		
TD3-24.5-25-WC05	24.5	25	149.5	75.5	93.5	WC**050308		
TD3-25-25-WC05	25	25	152	77	96	WC**050308		
TD3-25-32-WC05	25	32	161	77	101	WC**050308		
TD3-25.5-32-WC05	25.5	32	162.5	78.5	102.5	WC**050308		
TD3-26-32-WC05	26	32	164	80	104	WC**050308		
TD3-26.5-32-WC05	26.5	32	165.5	81.5	105.5	WC**050308		
TD3-27-32-WC05	27	32	167	83	107	WC**050308		
TD3-27.5-32-WC05	27.5	32	168.5	84.5	108.5	WC**050308		
TD3-28-32-WC05	28	32	170	86	110	WC**050308	M3.5*10	T15
TD3-28.5-32-WC05	28.5	32	171.5	87.5	111.5	WC**050308		
TD3-29-32-WC05	29	32	173	89	113	WC**050308		
TD3-29.5-32-WC05	29.5	32	174.5	90.5	114.5	WC**050308		
TD3-30-32-WC05	30	32	176	92	116	WC**050308		
TD3-30.5-32-WC05	30.5	32	176.5	93.5	116.5	WC**050308		
TD3-31-32-WC06	31	32	178	95	118	WC**06T308		
TD3-31.5-32-WC06	31.5	32	178.5	96.5	118.5	WC**06T308		
TD3-32-32-WC06	32	32	181	98	121	WC**06T308		
TD3-32.5-32-WC06	32.5	32	181.5	99.5	121.5	WC**06T308		
TD3-33-32-WC06	33	32	184	101	124	WC**06T308		
TD3-33.5-32-WC06	33.5	32	184.5	102.5	124.5	WC**06T308		
TD3-34-32-WC06	34	32	186	104	126	WC**06T308		
TD3-34.5-32-WC06	34.5	32	186.5	105.5	126.5	WC**06T308		
TD3-35-32-WC06	35	32	190	107	130	WC**06T308		
TD3-35.5-32-WC06	35.5	32	190.5	108.5	130.5	WC**06T308		
TD3-36-32-WC06	36	32	193	110	133	WC**06T308		
TD3-36.5-32-WC06	36.5	32	194.5	111.5	134.5	WC**06T308		
TD3-37-32-WC06	37	32	196	113	136	WC**06T308		



Тип	Размеры (мм)					Пластина	Запчасти			
	D	L1	L	L2	d		винт	ключ		
TD3-37.5-32-WC06	37.5	32	198.5	114.5	138.5	WC**06T308	M3.5*10	T15		
TD3-38-32-WC06	38	32	196.5	116	136.5	WC**06T308				
TD3-38.5-32-WC06	38.5	32	198	117.5	138	WC**06T308				
TD3-39-32-WC06	39	32	197	119	137	WC**06T308				
TD3-39.5-32-WC06	39.5	32	199.5	120.5	139.5	WC**06T308				
TD3-40-32-WC06	40	32	200	122	140	WC**06T308				
TD3-40.5-32-WC06	40.5	32	200.5	123.5	140.5	WC**06T308				
TD3-41-32-WC06	41	32	205	125	145	WC**06T308				
TD3-41.5-32-WC06	41.5	32	203.5	126.5	143.5	WC**06T308				
TD3-65-40-WC06	65	40	298.5	197	228.5	WC**06T308				
TD3-68-40-WC06	68	40	308	206	238	WC**06T308				
TD3-70-40-WC06	70	40	302	212	232	WC**06T308				
TD3-42-40-WC08	42	40	223	128	153	WC**080412			M4.0*10	T15
TD3-42.5-40-WC08	42.5	40	224.5	129.5	154.5	WC**080412				
TD3-43-40-WC08	43	40	226	131	156	WC**080412				
TD3-43.5-40-WC08	43.5	40	227.5	132.5	157.5	WC**080412				
TD3-44-40-WC08	44	40	229	134	159	WC**080412				
TD3-44.5-40-WC08	44.5	40	230.5	135.5	160.5	WC**080412				
TD3-45-40-WC08	45	40	232	137	162	WC**080412				
TD3-45.5-40-WC08	45.5	40	233.5	138.5	163.5	WC**080412				
TD3-46-40-WC08	46	40	235	140	165	WC**080412				
TD3-46.5-40-WC08	46.5	40	236.5	141.5	166.5	WC**080412				
TD3-47-40-WC08	47	40	238	143	168	WC**080412				
TD3-47.5-40-WC08	47.5	40	239.5	144.5	169.5	WC**080412				
TD3-48-40-WC08	48	40	241	146	171	WC**080412				
TD3-48.5-40-WC08	48.5	40	242.5	147.5	172.5	WC**080412				
TD3-49-40-WC08	49	40	244	149	174	WC**080412				
TD3-49.5-40-WC08	49.5	40	245.5	150.5	175.5	WC**080412				
TD3-50-40-WC08	50	40	247	152	177	WC**080412				
TD3-50.5-40-WC08	50.5	40	249	154	179	WC**080412				
TD3-51-40-WC08	51	40	250	155	180	WC**080412				
TD3-52-40-WC08	52	40	253	158	183	WC**080412				
TD3-53-40-WC08	53	40	256	161	186	WC**080412				
TD3-54-40-WC08	54	40	259	164	189	WC**080412				
TD3-55-40-WC08	55	40	262	167	192	WC**080412				
TD3-56-40-WC08	56	40	265	170	195	WC**080412				
TD3-57-40-WC08	57	40	268	173	198	WC**080412				
TD3-58-40-WC08	58	40	271	176	201	WC**080412				
TD3-59-40-WC08	59	40	274	179	204	WC**080412				
TD3-60-40-WC08	60	40	277	182	207	WC**080412				

Пластины

Обозначение			Обозначение		Подача, мм/об
ISO P	ISO M	ISO K	ISO N		
WCMX030208-TM120			WCGX030208-AL-TN110		0,05-0,09
WCMX040208-TM120			WCGX040208-AL-TN110		0,05-0,09
WCMX050308-TM120			WCGX050308-AL-TN110		0,06-0,10
WCMX06T308-TM120			WCGX06T308-AL-TN110		0,08-0,16
WCMX080412-TM120			WCGX080412-AL-TN110		0,10-0,20

P (Стали)				M (Нержавеющие стали)		K (Чугуны)			N
Углерод.	Низколег.	Высоколег.	Улучш.	Мартенсит.	Аустенит.	Ковкий	Серый	ВЧШГ	Al и Cu
170-240	140-220	120-180	120-170	110-230	110-220	120-220	170-240	130-200	250-300



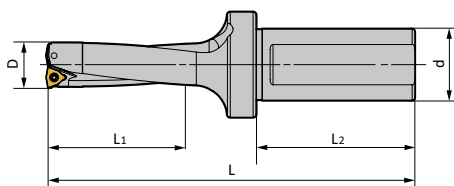

Тип	Размеры (мм)					Пластина	Запчасти			
	D	L1	L	L2	d		винт	ключ		
TD4-14-25-WC03	14	25	135	58	79	WC**030208	M2.5*5	T8		
TD4-14.5-25-WC03	14.5	25	137	60	81	WC**030208	M2.5*6	T8		
TD4-15-25-WC03	15	25	137	62	81	WC**030208				
TD4-15.5-25-WC03	15.5	25	139	64	83	WC**030208				
TD4-16-25-WC03	16	25	141	66	85	WC**030208				
TD4-16.5-25-WC03	16.5	25	143	68	87	WC**030208				
TD4-17-25-WC03	17	25	145	70	89	WC**030208				
TD4-17.5-25-WC03	17.5	25	147	72	91	WC**030208				
TD4-18-25-WC03	18	25	149	74	93	WC**030208				
TD4-18.5-25-WC03	18.5	25	151	76	95	WC**030208				
TD4-19-25-WC03	19	25	151	78	95	WC**030208				
TD4-19.5-25-WC04	19.5	25	153	80	97	WC**040208				
TD4-20-25-WC04	20	25	155.5	82	99.5	WC**040208				
TD4-20.5-25-WC04	20.5	25	158	84	102	WC**040208				
TD4-21-25-WC04	21	25	160	86	104	WC**040208				
TD4-21.5-25-WC04	21.5	25	162	88	106	WC**040208				
TD4-22-25-WC04	22	25	164	90	108	WC**040208				
TD4-22.5-25-WC04	22.5	25	166	92	110	WC**040208				
TD4-23-25-WC04	23	25	168	94	112	WC**040208				
TD4-23.5-25-WC04	23.5	25	170	96	114	WC**040208				
TD4-24-25-WC05	24	25	172	98	116	WC**050308	M3.0*8	T8		
TD4-24.5-25-WC05	24.5	25	174	100	118	WC**050308				
TD4-25-25-WC05	25	25	177	102	121	WC**050308				
TD4-25.5-32-WC05	25.5	32	188	104	128	WC**050308				
TD4-26-32-WC05	26	32	190	106	130	WC**050308				
TD4-26.5-32-WC05	26.5	32	192	108	132	WC**050308				
TD4-27-32-WC05	27	32	194	110	134	WC**050308				
TD4-27.5-32-WC05	27.5	32	196	112	136	WC**050308				
TD4-28-32-WC05	28	32	198	114	138	WC**050308				
TD4-28.5-32-WC05	28.5	32	200	116	140	WC**050308				
TD4-29-32-WC05	29	32	202	118	142	WC**050308				
TD4-29.5-32-WC05	29.5	32	204	120	144	WC**050308				
TD4-30-32-WC05	30	32	206	122	146	WC**050308				
TD4-30.5-32-WC05	30.5	32	207	124	147	WC**050308				
TD4-31-32-WC06	31	32	209	126	149	WC**050308			M3.5*10	T15
TD4-31.5-32-WC06	31.5	32	210	128	150	WC**06T308				
TD4-32-32-WC06	32	32	213	130	153	WC**06T308				
TD4-32.5-32-WC06	32.5	32	214	132	154	WC**06T308				
TD4-33-32-WC06	33	32	217	134	157	WC**06T308				
TD4-33.5-32-WC06	33.5	32	218	136	158	WC**06T308				
TD4-34-32-WC06	34	32	220	138	160	WC**06T308				
TD4-34.5-32-WC06	34.5	32	221	140	161	WC**06T308				
TD4-35-32-WC06	35	32	225	142	165	WC**06T308				
TD4-35.5-32-WC06	35.5	32	226	144	166	WC**06T308				
TD4-36-32-WC06	36	32	229	146	169	WC**06T308				
TD4-36.5-32-WC06	36.5	32	231	148	171	WC**06T308				
TD4-37-32-WC06	37	32	233	150	173	WC**06T308				
TD4-37.5-32-WC06	37.5	32	236	152	176	WC**06T308				



Тип	Размеры (мм)					Пластина	Запчасти	
	D	L1	L	L2	d		винт	ключ
TD4-38-32-WC06	38	32	234.5	154	174.5	WC**06T308	M3.5*10	T15
TD4-38.5-32-WC06	38.5	32	236.5	156	176.5	WC**06T308		
TD4-39-32-WC06	39	32	240	158	180	WC**06T308		
TD4-39.5-32-WC06	39.5	32	239	160	179	WC**06T308		
TD4-40-32-WC06	40	32	240	162	180	WC**06T308		
TD4-40.5-32-WC06	40.5	32	241	164	181	WC**06T308		
TD4-41-32-WC06	41	32	246	166	186	WC**06T308		
TD4-41.5-32-WC06	41.5	32	245	168	185	WC**06T308		
TD4-65-40-WC06	65	40	363.5	262	293.5	WC**06T308		
TD4-68-40-WC06	68	40	376	274	306	WC**06T308		
TD4-70-40-WC06	70	40	372	282	302	WC**06T308		
TD4-42-40-WC08	42	40	265	170	195	WC**080412	M4.0*10	T15
TD4-42.5-40-WC08	42.5	40	267	172	197	WC**080412		
TD4-43-40-WC08	43	40	269	174	199	WC**080412		
TD4-43.5-40-WC08	43.5	40	271	176	201	WC**080412		
TD4-44-40-WC08	44	40	273	178	203	WC**080412		
TD4-44.5-40-WC08	44.5	40	275	180	205	WC**080412		
TD4-45-40-WC08	45	40	277	182	207	WC**080412		
TD4-45.5-40-WC08	45.5	40	279	184	209	WC**080412		
TD4-46-40-WC08	46	40	281	186	211	WC**080412		
TD4-46.5-40-WC08	46.5	40	283	188	213	WC**080412		
TD4-47-40-WC08	47	40	285	190	215	WC**080412		
TD4-47.5-40-WC08	47.5	40	287	192	217	WC**080412		
TD4-48-40-WC08	48	40	289	194	219	WC**080412		
TD4-48.5-40-WC08	48.5	40	291	196	221	WC**080412		
TD4-49-40-WC08	49	40	293	198	223	WC**080412		
TD4-49.5-40-WC08	49.5	40	295	200	225	WC**080412		
TD4-50-40-WC08	50	40	297	202	227	WC**080412		
TD4-50.5-40-WC08	50.5	40	299	204	229	WC**080412		
TD4-51-40-WC08	51	40	301	206	231	WC**080412		
TD4-52-40-WC08	52	40	305	210	235	WC**080412		
TD4-53-40-WC08	53	40	309	214	239	WC**080412		
TD4-54-40-WC08	54	40	313	218	243	WC**080412		
TD4-55-40-WC08	55	40	317	222	247	WC**080412		
TD4-56-40-WC08	56	40	321	226	251	WC**080412		
TD4-57-40-WC08	57	40	325	230	255	WC**080412		
TD4-58-40-WC08	58	40	329	234	259	WC**080412		
TD4-59-40-WC08	59	40	333	238	263	WC**080412		
TD4-60-40-WC08	60	40	337	242	267	WC**080412		

Пластины

Обозначение			Обозначение		Подача, мм/об
ISO P	ISO M	ISO K	ISO N		
WCMX030208-TM120			WCGX030208-AL-TN110		0,05-0,09
WCMX040208-TM120			WCGX040208-AL-TN110		0,05-0,09
WCMX050308-TM120			WCGX050308-AL-TN110		0,06-0,10
WCMX06T308-TM120			WCGX06T308-AL-TN110		0,08-0,16
WCMX080412-TM120			WCGX080412-AL-TN110		0,10-0,20

P (Стали)				M (Нержавеющие стали)		K (Чугуны)			N
Углерод.	Низколег.	Высоколег.	Улучш.	Мартенсит.	Аустенит.	Ковкий	Серый	ВЧШГ	Al и Cu
170-240	140-220	120-180	120-170	110-230	110-220	120-220	170-240	130-200	250-300



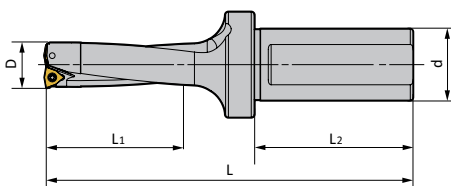

Тип	Размеры (мм)					Пластина	Запчасти			
	D	L1	L	L2	d		винт	ключ		
TD5-14-25-WC03	14	25	149	72	93	WC**030208	M2.5*5	T8		
TD5-14.5-25-WC03	14.5	25	151.5	74.5	95.5	WC**030208	M2.5*6	T8		
TD5-15-25-WC03	15	25	152	77	96	WC**030208				
TD5-15.5-25-WC03	15.5	25	154.5	79.5	98.5	WC**030208				
TD5-16-25-WC03	16	25	157	82	101	WC**030208				
TD5-16.5-25-WC03	16.5	25	159.5	84.5	103.5	WC**030208				
TD5-17-25-WC03	17	25	162	87	106	WC**030208				
TD5-17.5-25-WC03	17.5	25	164.5	89.5	108.5	WC**030208				
TD5-18-25-WC03	18	25	167	92	111	WC**030208				
TD5-18.5-25-WC03	18.5	25	169.5	94.5	113.5	WC**030208				
TD5-19-25-WC03	19	25	170	97	114	WC**030208				
TD5-19.5-25-WC04	19.5	25	172.5	99.5	116.5	WC**040208				
TD5-20-25-WC04	20	25	175.5	102	119.5	WC**040208				
TD5-20.5-25-WC04	20.5	25	178.5	104.5	122.5	WC**040208				
TD5-21-25-WC04	21	25	181	107	125	WC**040208				
TD5-21.5-25-WC04	21.5	25	183.5	109.5	127.5	WC**040208				
TD5-22-25-WC04	22	25	186	112	130	WC**040208				
TD5-22.5-25-WC04	22.5	25	188.5	114.5	132.5	WC**040208				
TD5-23-25-WC04	23	25	191	117	135	WC**040208				
TD5-23.5-25-WC04	23.5	25	193.5	119.5	137.5	WC**040208				
TD5-24-25-WC05	24	25	196	122	140	WC**050308	M3.0*8	T8		
TD5-24.5-25-WC05	24.5	25	198.5	124.5	142.5	WC**050308				
TD5-25-25-WC05	25	25	202	127	146	WC**050308				
TD5-25-32-WC05	25	32	211	127	151	WC**050308				
TD5-25.5-32-WC05	25.5	32	213.5	129.5	153.5	WC**050308				
TD5-26-32-WC05	26	32	216	132	156	WC**050308				
TD5-26.5-32-WC05	26.5	32	218.5	134.5	158.5	WC**050308				
TD5-27-32-WC05	27	32	221	137	161	WC**050308				
TD5-27.5-32-WC05	27.5	32	223.5	139.5	163.5	WC**050308				
TD5-28-32-WC05	28	32	226	142	166	WC**050308				
TD5-28.5-32-WC05	28.5	32	228.5	144.5	168.5	WC**050308				
TD5-29-32-WC05	29	32	231	147	171	WC**050308				
TD5-29.5-32-WC05	29.5	32	233.5	149.5	173.5	WC**050308				
TD5-30-32-WC05	30	32	236	152	176	WC**050308				
TD5-30.5-32-WC05	30.5	32	237.5	154.5	177.5	WC**050308				
TD5-31-32-WC06	31	32	240	157	180	WC**06T308			M3.5*10	T15
TD5-31.5-32-WC06	31.5	32	241.5	159.5	181.5	WC**06T308				
TD5-32-32-WC06	32	32	245	162	185	WC**06T308				
TD5-32.5-32-WC06	32.5	32	246.5	164.5	186.5	WC**06T308				
TD5-33-32-WC06	33	32	250	167	190	WC**06T308				
TD5-33.5-32-WC06	33.5	32	251.5	169.5	191.5	WC**06T308				
TD5-34-32-WC06	34	32	254	172	194	WC**06T308				
TD5-34.5-32-WC06	34.5	32	255.5	174.5	195.5	WC**06T308				
TD5-35-32-WC06	35	32	260	177	200	WC**06T308				
TD5-35.5-32-WC06	35.5	32	261.5	179.5	201.5	WC**06T308				
TD5-36-32-WC06	36	32	265	182	205	WC**06T308				
TD5-36.5-32-WC06	36.5	32	267.5	184.5	207.5	WC**06T308				
TD5-37-32-WC06	37	32	270	187	210	WC**06T308				



Тип	Размеры (мм)					Пластина	Запчасти			
	D	L1	L	L2	d		винт	ключ		
TD5-37.5-32-WC06	37.5	32	273.5	189.5	213.5	WC**06T308	M3.5*10	T15		
TD5-38-32-WC06	38	32	272.5	192	212.5	WC**06T308				
TD5-38.5-32-WC06	38.5	32	275	194.5	215	WC**06T308				
TD5-39-32-WC06	39	32	279	197	219	WC**06T308				
TD5-39.5-32-WC06	39.5	32	278.5	199.5	218.5	WC**06T308				
TD5-40-32-WC06	40	32	280	202	220	WC**06T308				
TD5-40.5-32-WC06	40.5	32	281.5	204.5	221.5	WC**06T308				
TD5-41-32-WC06	41	32	287	207	227	WC**06T308				
TD5-41.5-32-WC06	41.5	32	286.5	209.5	226.5	WC**06T308				
TD5-65-40-WC06	65	40	428.5	327	358.5	WC**06T308				
TD5-68-40-WC06	68	40	444	342	374	WC**06T308				
TD5-70-40-WC06	70	40	452	352	372	WC**06T308				
TD5-42-40-WC08	42	40	307	212	237	WC**080412			M4.0*10	T15
TD5-42.5-40-WC08	42.5	40	309.5	214.5	239.5	WC**080412				
TD5-43-40-WC08	43	40	312	217	242	WC**080412				
TD5-43.5-40-WC08	43.5	40	314.5	219.5	244.5	WC**080412				
TD5-44-40-WC08	44	40	317	222	247	WC**080412				
TD5-44.5-40-WC08	44.5	40	319.5	224.5	249.5	WC**080412				
TD5-45-40-WC08	45	40	322	227	252	WC**080412				
TD5-45.5-40-WC08	45.5	40	324.5	229.5	254.5	WC**080412				
TD5-46-40-WC08	46	40	327	232	257	WC**080412				
TD5-46.5-40-WC08	46.5	40	329.5	234.5	259.5	WC**080412				
TD5-47-40-WC08	47	40	332	237	262	WC**080412				
TD5-47.5-40-WC08	47.5	40	334.5	239.5	264.5	WC**080412				
TD5-48-40-WC08	48	40	337	242	267	WC**080412				
TD5-48.5-40-WC08	48.5	40	339.5	244.5	269.5	WC**080412				
TD5-49-40-WC08	49	40	342	247	272	WC**080412				
TD5-49.5-40-WC08	49.5	40	344.5	249.5	274.5	WC**080412				
TD5-50-40-WC08	50	40	347	252	277	WC**080412				
TD5-50.5-40-WC08	50.5	40	349.5	254.5	279.5	WC**080412				
TD5-51-40-WC08	51	40	352	257	282	WC**080412				
TD5-52-40-WC08	52	40	357	262	287	WC**080412				
TD5-53-40-WC08	53	40	362	267	292	WC**080412				
TD5-54-40-WC08	54	40	367	272	297	WC**080412				
TD5-55-40-WC08	55	40	372	277	302	WC**080412				
TD5-56-40-WC08	56	40	377	282	307	WC**080412				
TD5-57-40-WC08	57	40	382	287	312	WC**080412				
TD5-58-40-WC08	58	40	387	292	317	WC**080412				
TD5-59-40-WC08	59	40	392	297	322	WC**080412				
TD5-60-40-WC08	60	40	397	302	327	WC**080412				

Пластины

Обозначение			Обозначение	Подача, мм/об
ISO P	ISO M	ISO K	ISO N	
WCMX030208-TM120			WCGX030208-AL-TN110	0,05-0,09
WCMX040208-TM120			WCGX040208-AL-TN110	0,05-0,09
WCMX050308-TM120			WCGX050308-AL-TN110	0,06-0,10
WCMX06T308-TM120			WCGX06T308-AL-TN110	0,08-0,16
WCMX080412-TM120			WCGX080412-AL-TN110	0,10-0,20

P (Стали)				M (Нержавеющие стали)		K (Чугуны)			N
Углерод	Низколег.	Высоколег.	Улучш.	Мартенсит.	Аустенит.	Ковкий	Серый	ВЧШГ	Al и Cu
170-240	140-220	120-180	120-170	110-230	110-220	120-220	170-240	130-200	250-300



Эксцентриковая втулка

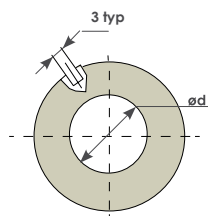
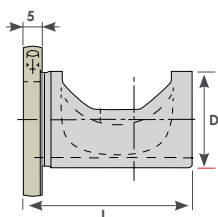

ОБОЗНАЧЕНИЕ	D	d	L
SLD2520	25	20	44
SLD3225	32	25	46
SLD4032	40	32	55

ТЕХНИЧЕСКАЯ ИНФОРМАЦИЯ

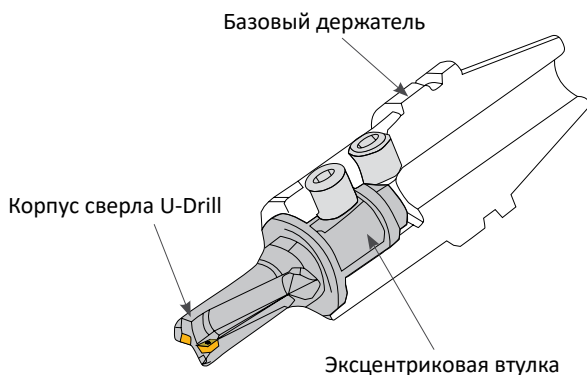

Диаметр отверстия 24,8 мм

Диаметр отверстия 25,4 мм



Диаметр сверла 25 мм

Диаметр сверла 25 мм



Эксцентриковая втулка

При использовании на фрезерном станке эксцентриковой втулки номинальный диаметр сверла может быть изменен. Это возможно за счет смещения оси инструмента относительно оси вращения шпинделя.

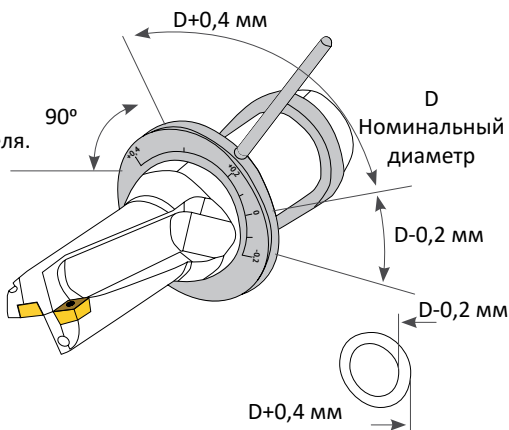
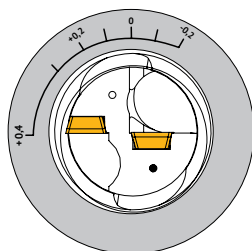

Для радиального регулирования можно использовать любой подходящий штифт. Например, шестигранный ключ.

Регулировка диаметра сверла с помощью эксцентриковой втулки осуществляется следующим образом:

1. Обязательно совместите лыску на сверле с отметкой на втулке "0", таким образом чтобы получился прямой угол.
2. Произведите регулировку диаметра, вращая втулку по часовой или против часовой стрелки.
3. Закрепите инструмент в базовом патроне.

Обратите внимание:

1. Возможно использовать только базовые держатели WELDON.
2. Перед началом регулировки раскрепите инструмент в базовом держателе.
3. Точность регулировки зависит от квалификации исполнителя.